

## MS-12 VACUUM MOTOR

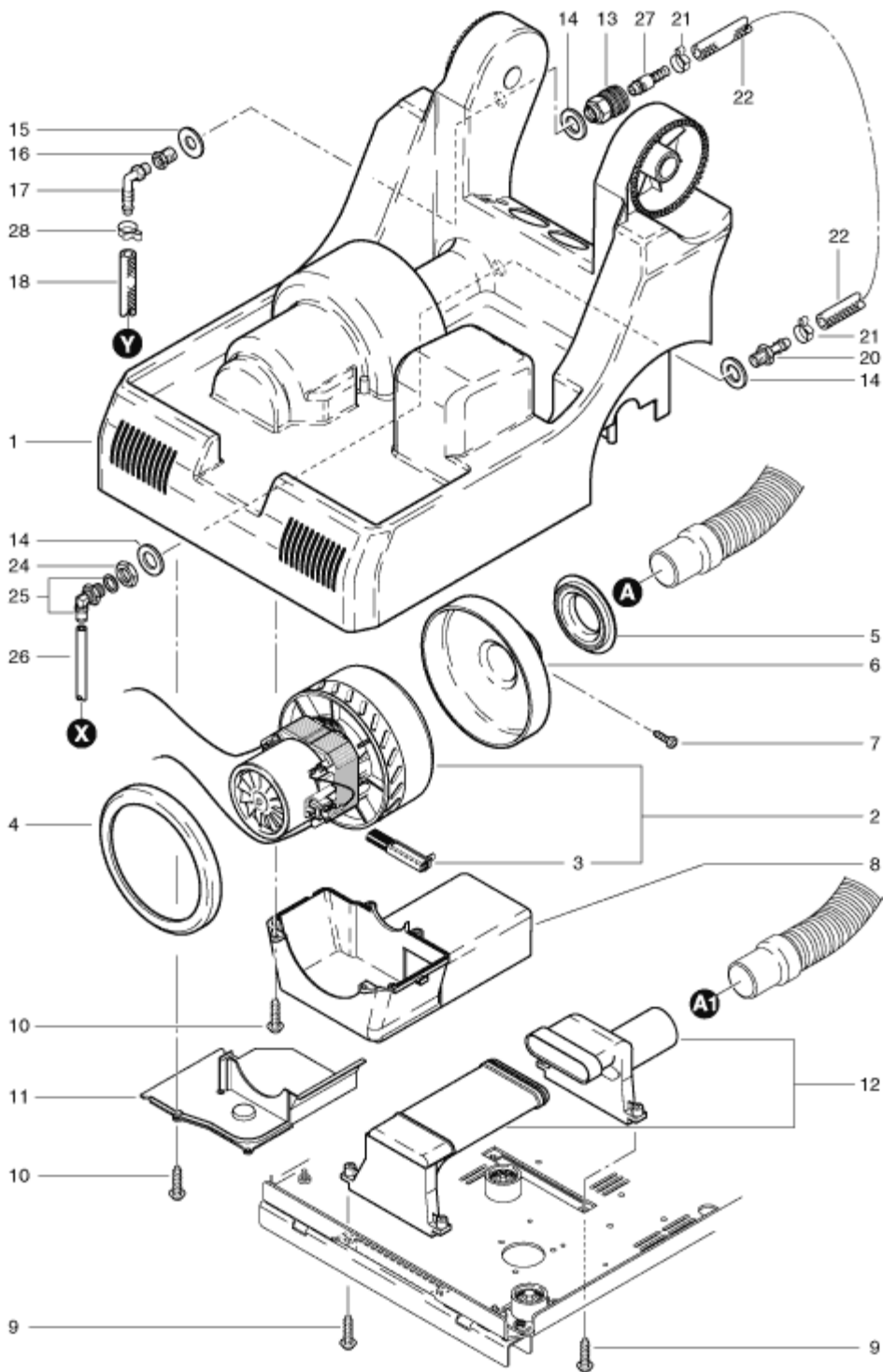

Pos.	Description	Reference
01	Chassis cover	300.052
02	Suction motor	P...870C
03	Pair of Charbon brushes	P...870X
04	Motor sealing ring	P...971C
05	Sealing ring	380.019
06	Hose connection cap	380.021
07	Screw 2.9x9.5 mm	P...483H
08	Motor cover	380.017
09	PT-screw KA 50x16 mm	P...515Z
10	PT-screw KA 40x18 mm	P...516C
11	Air canal cover	380.022
12	Air canal compl.	300.410
13	Coupling	380.045
14	Security ring	P...098
15	Washer M12	P...496A
16	Reducer	P...521E
17	Angled connector	P...541R
18	Pressure hose 6/12x420 mm	300.178
20	Connecting nipple	300.088
21	Hose clamp 14.5 mm	P...550A
22	Connection hose 250 mm	300.172
24	Hexagon nut 3/8««	P...535B
25	Angled connector	P...533C
26	Connection hose 640 mm	300.165
27	Straight nipple with reducer	300.085
28	Hose clamp 13.3 mm	P...550I